

Shipping & Delivery

- Please be assured that all **in stock items will ship out within 3 days** of purchase. We determine the most efficient shipping carrier for your order unless otherwise specified. The carriers that may be used are: U.S. Postal Service (USPS) or United Parcel Service (UPS).
- Receiver and slide deliveries may vary-. Please call for current lead times.
- **Credit card authorization and verification must be received prior to processing.** UPS deliveries occur Monday through Friday, excluding holidays.
- All orders require delivery conformation. UPS will ship direct delivery and adult signature.
- **We do not send major components** through the U.S. Postal Service.
- If you require Express or Next Day shipping, please call us at 802-472-6454 for charges and availability.

Shipping based on 1lb packages

UPS Ground.....\$25.00 UPS 3 Day\$35.00

UPS 2 Day\$45.00 UPS Next Day.....\$65.00

Priority Mail.....\$10.25

Quantity Schedule

- Apply discount to individual parts **per order.**

Quantity	Discount
1-9.....	%0
10-24.....	%5
25-49.....	%10
50-100.....	%15
Distributor/OEM.....	Call

- Discounts do not apply to Damascus products or services.



Caspian

ARMS LTD.

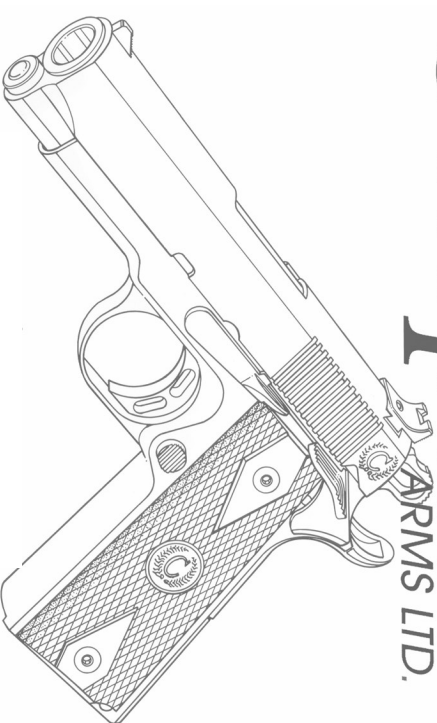

CASPIAN ARMS LTD.

MADE IN THE USA

Caspian Arms has been serving the American Pistolsmith since 1983 by providing top quality 1911 frames, slides, and small parts.

Call or Email to place an order today!

Email: sales@caspianarms.com

Phone: 802-472-6454

Caspian Arms Ltd.

75 Cal Foster Dr.

Wolcott, VT 05680

Who we are

Caspian Arms Ltd. has been supplying precision components for firearms since 1983. Here in our Vermont machine shop our products are made from U.S. materials such as barstock, castings or forgings. Our shop is equipped with some of the latest CNC machines bringing you the highest quality parts.

- We offer components that are "made to order" with an abundance of luxury options, designs and material choices. More than any other manufacturer to insure you can complete the most top of the line custom pistol.
- **LOOKING FOR A BARGAIN?** Give us a call to see what we have for specials.

Warranty

- **All slides are guaranteed for life.** Machine operations such as lightening cuts, or additional lowering of ejection port will void your warranty. It's our call. In some cases we may offer a partial credit.
- Steel frames of all types are **guaranteed for life** against cracking. Cracks caused by obvious modifications will void the warranty.
- All our small parts carry a **lifetime warranty**.
- **Invoice or Invoice Number Required For Warranty Replacement**

Policies

- A **15%** non refundable deposit will be charged on **all orders as well as custom slide & receiver orders**.
- Please inspect your order carefully when you receive it. Contact us at 1-802-472-6454 right away if you are not satisfied. We will accept items for refund, credit or exchange if they are returned to us within **30 days** in unused condition. **For all items returned beyond 30 days of the purchase date we will apply a 15% restocking fee.**
- It is illegal to export firearms and firearm components without a State Department License. A FFL is required and all receivers are required to be sent to a valid FFL Holder.

Double Stack Receiver Components



Double Stack Ambi Safety

Specifically designed for our double stack receiver, carbon steel.

Double stack ambi safety
R162B.....\$40.00



Double Stack Grip Safety

Unbeatable speed bump guarantees your gun will fire in the heat of competition.

Carbon double stack grip safety
R332B.....\$50.00



Double Stack Mag Catch

The perfect extension.

Double stack mag catch
R92B.....\$40.00



Double Stack Trigger

Great light weight skeletonized, flat faced aluminum shoe, with a rigid no flex stainless bow.

Double stack trigger
R10HT.....\$40.00

Double Stack Magazines are available through

www.mbxextreme.com/Caspian/Tanfoglio

Double Stack Receiver Components

Double Stack Kit

Shooters find that the ultra thin design of our no flexing recoil reducing steel frame gives them the control they need to win. Our Double Stack has an expanded magwell and integral plunger tube.



Double Stack Recon Kit

"Special purpose" takes on a new meaning when you consider the potential of this kit. The combined advantage of double stack, light capability, expanded magwell, and integral plunger tube leaves nothing to be desired.



Carbon Steel \$580.00
Titanium \$880.00

Carbon Steel \$680.00

Titanium \$1,025.00

Double Stack Receivers w/o parts kit

Double Stack, Carbon Steel \$410.00

Double Stack, Titanium \$710.00

Recon Double Stack, Carbon Steel \$510.00

Recon Double Stack, Titanium \$855.00

Double Stack/Race Ready Mainspring Housing

Extended to fit into the expanded Magwell on our race ready and double stack receivers. Please specify arched or flat.

Carbon or stainless..... \$40.00

Add checkering :see pricing on page 19

20 LPI, 25LPI, 30LPI, knurling or diamond plate only available on flat mainspring housings.

Integral lanyard loop.....\$25.00

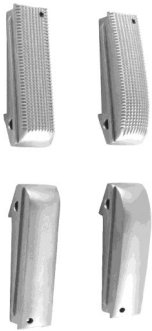

Medallions

Caspian medallion pair.

Medallion MDJS2.....\$10.00

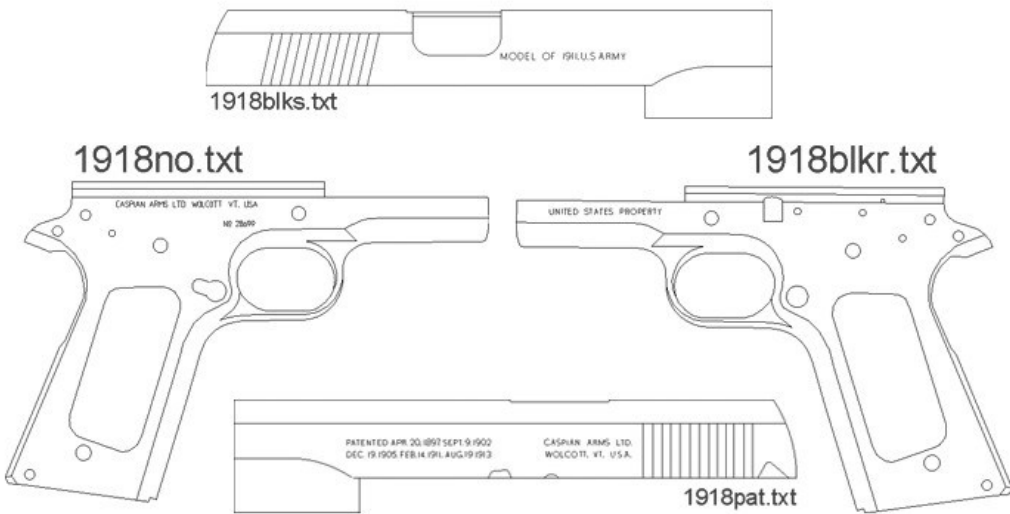

Custom Engraving

We also offer a selection of classic style Engravings for your retro build.

1918BLKS.....\$30.00
1918NO.....\$80.00

1918PAT.....\$30.00
1918BLKR.....\$30.00

Classic Slides are drill for the traditional .45acp firing pin hole, high window and no flare on the ejection port. Caspian or large logos are not available behind the rear serrations.

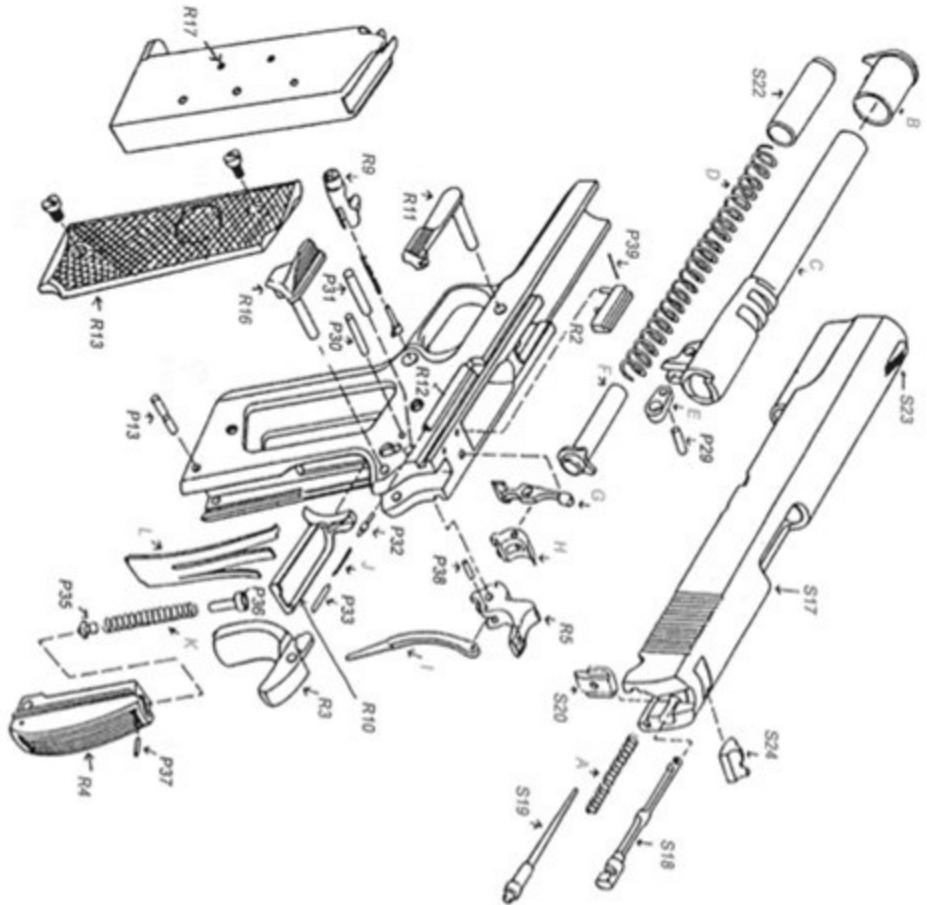

Pin Sets

This 11 piece set contains all the pins and plungers for your pistol, including a solid ejector Pin, Turned Right here in house, and heat treated to max.

Carbon pin set

P28BC.....\$25.00

Stainless pin set

P28SC.....\$30.00



Oversized Pin Sets

Oversized 3pc Set, Includes: Hammer pin, Sear pin and Link pin. Carbon or 17-4 Stainless Steel, Hardened to 40RC range

Carbon oversized pin set

P28B0CA.....\$10.00

Stainless oversized pin set

P28S0CA.....\$15.00



Officer Pin Sets

Officer's 2 pc Set, Includes: Mainspring Housing Pin Retainer and Mainspring Housing Cap, Carbon Steel.

Officer pin set

P280BA.....\$20.00



Receiver Components

Ejectors

Ejector 38s/9mm and 10mm/40sw or 45acp. Machined from Barstock and heat treated to RC 42.

Caspian Officer/Commander slides are cut for a .38s/9mm ejector ramp requiring a .38s/9mm ejector in the .45acp slides.

Carbon ejectors R238B/R245B\$30.00

Stainless ejectors R238S/R245S.....\$35.00

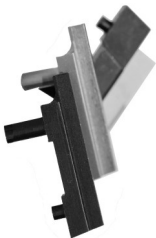

Ejector 38s/9mm Extra Long

Extra long design is intended for tuning the 9mm family of pistols. Recommended for professional installation only.

Extra long ejector R238L.....\$35.00



Grip Screws and Bushings

Stainless grip screws R141S.....\$15.00

Carbon grip screws R141B.....\$15.00

Stainless bushings R151S.....\$15.00

Carbon bushings R151B.....\$15.00



Scope Mounts

Caspian scope mount.

Scope mount

A02W10.....\$85.00

Scope mount screws, set of 10pcs

A02S.....\$15.00



We are proud to display our American Pistolsmiths Guild
"Seal of Approval".

Our forgings are made from USA material of certified 4340 hi-carbon steel or 416 stainless steel. Struck on Caspian dies and pre-heat treated to 37-41 RC before they ever see a cutting tool to insure first class stability. Multi-station inspections greatly improve quality control. All Caspian slides are drilled for the 38s/9mm firing pin hole, to make our slides more versatile and to prevent primer flow. All Officer and Commander Slides are cut for a 38s/9mm ejection ramp. Therefore require the 38s/9mm ejector and firing pin retainer.

Life time guarantee you just can't buy a stronger, more precisely machined unit. No one holds their rail specs and hole location closer than Caspian. Our 30 plus years of experience assure the right choice of material at the right heat treat for optimum performance. It's easy to see that Caspian receivers are the best choice for building your one of a kind gun. We offer more options than any other competitor on the market. Available in all popular models and calibers.

Slide Components

S18 Extractor

S19 Firing Pin

S20 Firing Pin Retainer

S22 Standard Guide Plugs

S23 Front Sight

S24 Rear Sight

Only Available as Double Stack

R9 Mag Catch

R16 Ambi Safety

Not Listed in Catalog

A Firing Pin Spring

B Barrel Bushing

C Barrel

D Recoil Spring

E Barrel Link

F Recoil Spring Guide

G Disconnecter

H Sear

I Strut

J Plunger Spring

K Main Spring

L Sear Spring

M. Slide Stop

N. Wood Grips

Receiver Components

R2 Ejector

R3 Grip Safety

R4 Mainspring Housing

R5 Hammer

R10 Trik Trigger

R12 Plunger Tubes

Pins –11pc Pins & Plungers

P29 Barrel Lin Pin

P30 Sear Pin

P31 Hammer Pin

P32 Slide Stop Plunger

P33 Safety Lock Plunger

P34 Mainspring Housing Pin

P35 Housing Pin Retainer

P36 Mainspring Housing Cap

P37 Mainspring Housing Cap Pin

P38 Hammer Strut Pin

P39 Ejector Pin

When Ordering Caspian Slides

- Caliber's available: .38s/9mm, 40sw/10mm & 45acp.
 - All Caspian slides are drilled for the 9mm/38s firing pin hole except Classic Slides.
 - Model's available: 3.5" Officer, 4.25 Commander 5" Government and 6" long.
- Please specify .700 or .760 Bore and with or without the bushing notch cut when ordering the Officer model slide*
- Officer & Commander slides are cut for the 38s/9mm ejection ramp requiring 38s/9mm Ejector and Firing Pin Retainer.
 - Caspian slides are engraved with logos unless otherwise specified.
 - Caspian rear serrations come standard unless otherwise specified.
 - Slides have the standard front radius unless otherwise specified.
 - Slides are all Series 70 unless otherwise specified.
 - Slides all have the internal extractor cut unless otherwise specified.
 - **Bald Slides without sight cuts but with serrations**
 - **Bare Slides without sight cuts or serrations**

Damascus Slides

This legendary material is as durable as it is stunning, no two patterns are alike. Beautiful Damascus imported from Sweden available in all sizes and calibers. See small parts for individual parts available in Damascus.

Made to order, please call for estimated lead times. They are worth the wait.

Officer, Commander and Government models\$950.00
6" Long Slide.....\$1,125.00

Shown in commander model with Caspian style front and rear serrations. Options shown are available for an additional charge. Caspian logos are intentional omitted on Damascus.



Receiver Components

Damascus Trik Trigger

This blank shoe looks great embellished by your gunsmith or left as is. Bow is from the same Videki tooling as our Trik Trigger so you know its right.



Damascus 1911 trigger
 R10D.....\$125.00

Trik Trigger

Now made in house our newly designed Trik Trigger is easy to fit, equipped with "Drag Strips" on top and bottom for less friction and drag.



Stainless steel bow with skeletonized aluminum shoe. This design is extremely comfortable and offers excellent control.

Trik Trigger
 R10T2.....\$40.00

Plunger Tube

GI Spec, will also function well in optional slot cut.



Carbon R121B.....\$15.00
Stainless R121S.....\$15.00

Grip Safeties

Unbeatable design feels good in your hand. Extra meat on the paddle allows for custom contouring for those who like a high grip. Speed bump grip safety please specify Caspian or .250 radius.



Carbon.....\$45.00
Stainless.....\$50.00

Receiver Components

Damascus 1911 Hammer

Machined on EDM-ed blanks.
Heat treated to RC 60.



Damascus 1911 hammer
R51D.....\$130.00

Combat Style 1911 Hammer

Machined on EDM-ed blanks.
Heat treated to RC 60.



Combat Style 1911 hammer
R5B1B.....\$65.00

Damascus Mainspring Housing

1911 style mainspring housing, made from our beautiful Damascus Material. Only available flat.

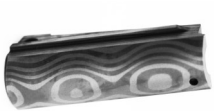

Damascus mainspring housing
R42FDS.....\$125.00

Mainspring Housing

Mainspring housings manufactured for the 1911 single stack receiver. Please specify arched or flat.



Mainspring housing
Carbon.....\$40.00
stainless.....\$45.00

Add checking : see pricing on page 19

20 LP1, 25LP1, 30LP1, knurling or diamond plate only available on flat mainspring housings.

Logos

Caspian slides come with the "C" logos on both sides behind the serrations as well as our company "Caspian" on the left side. You may also order your slide with one or the other or with no logos at all.

Please see **custom engraving** for more options.

Slides

Available in 3.5" Officer, 4.25" Commander and 5" Government

Carbon steel.....\$265.00
Stainless steel.....\$305.00



Classic Slides

The classic slide is perfect for those who wish to replicate the basic beauty of the early 1911's. The classic slides have original style vertical serrations, standard ejection port, GI style sight cuts and no logos.

Carbon steel.....\$285.00
Stainless steel.....\$325.00

Shown in stainless steel with classic vertical rear serrations. Options shown are available for an additional charge.



Long Slides

6" long slides are heat treated early on in the manufacturing process to insure dimensional stability. Popular in PPC and Bullseye circles, the six inch slide is now showing up at IPSC venues. Extra weight over the muzzle reduces flip, longer sight radius helps accuracy and longer barrel increases velocity.

Carbon steel.....\$330.00
Stainless steel.....\$365.00

Shown in stainless steel with Caspian style rear serrations. Options are available for an additional charge.



Slide Profile Options

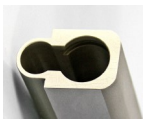

Crew
Crew Cut-square w/rounded corners on top of slide.
CREW.....\$60.00

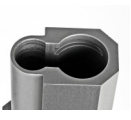

Hi & Tight
High & Tight-Top style on top of slide.
HI&TIGHT.....\$60.00



Square
Square cut on top of the slide.
SQUARE.....\$100.00

Front Radius Options

No Radius
The radius cut has not been machined creating a squared off front end, this adds weight to the front of the slide.

Standard Radius
The standard radius has the traditional radius machined scallop cut over the recoil plug housing.

Recon Radius
1/4" Ball radius cut that lines up with the end of the light rail on the Recon Receiver, makes a perfect match.

Ball Radius
1/4" Ball radius cut which creates a sharper radius for a less traditional look lining up with the dustcover

Regulation Trim

Regulation Trim "Hi-Power style" cut to the front profile of the slide

HP CUT.....\$30.00



Gunsmithing

Frame to Slide Fit

Hand fit, carbon.....\$105.00
Hand fit, stainless steel.....\$140.00
(Includes Tungsten Carbide Application to Receiver Rails)
CARB.....\$40.00
(Includes Tungsten Carbide Application to fitted Receiver Rails)

Parts Installation

Professional Part Installation
Ejectors, Plunger Tubes and Grip
Screw Bushings: Cost of Part and
additional charge of.....15.00

Custom Engraving

The perfect finishing touch to your custom gun. Custom engraving is available anywhere on the right or left side of the slide. Up to two lines with available fonts on file. All engraving is done on our CNC machines; not laser or hand etched. **note that all engravings are at Caspian's discretion and all pricing is subject to change.**

Custom engraving.....\$80.00

We also offer a selection of icon logos that sit behind the serrations. Call or email to be sent a chart of all available icon logos.

Icons.....\$30.00

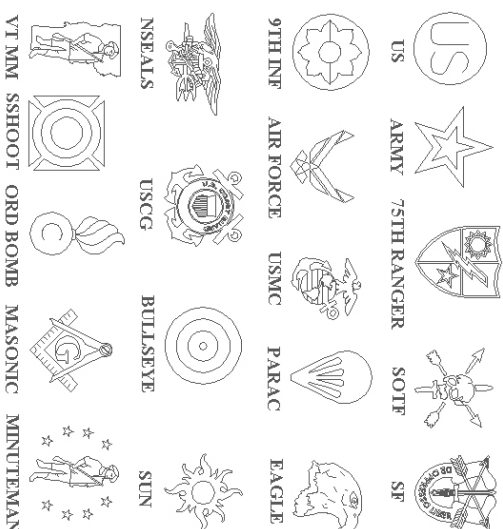

Receiver Texture Options

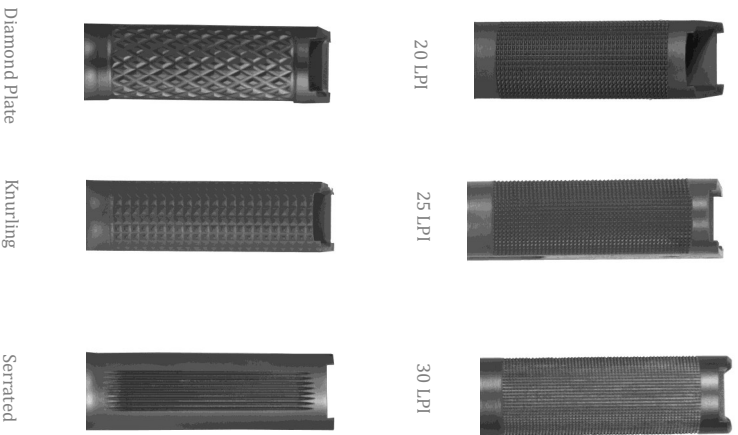

Front Strap Checking Options

Machine cut and hand burred, our checking options are a clean effective alternative to expensive hand checking. 20LPI is our most popular option the 25LPI is a more elegant choice and the 30LPI is both painless and attractive. Diamond plate checking offers that designer custom look while knurling delivers the most comfortable grip.

20LPI	\$105.00	Diamond Plate	\$105.00
25LPI	\$130.00	Knurling	\$105.00
30LPI	\$155.00	Serrated	\$45.00

Back Strap Checking Options

20lpi checking is available on both arched or flat mainspring housings. All other texturing is only available on the flat.

20LPI	\$50.00	Diamond Plate	\$50.00
25LPI	\$70.00	Knurling	\$50.00
30LPI	\$70.00	Serrated	\$25.00

Slide Texture Options

Caspian slides come the traditional smooth radius on the top of the slide. You may choose from the selection below to get the look that also reduces the glare.

- A Serrated round top** SERRROUND.....\$45.00
- B Serrated flat top** SERRFLAT.....\$85.00
- C Knurling flat top** KNFLAT.....\$85.00
- D Flat top** FLAT.....\$45.00
- E Diamond plate flat top** DPFLAT.....\$85.00
- F Rifling round top** RIFLETOP.....\$100.00

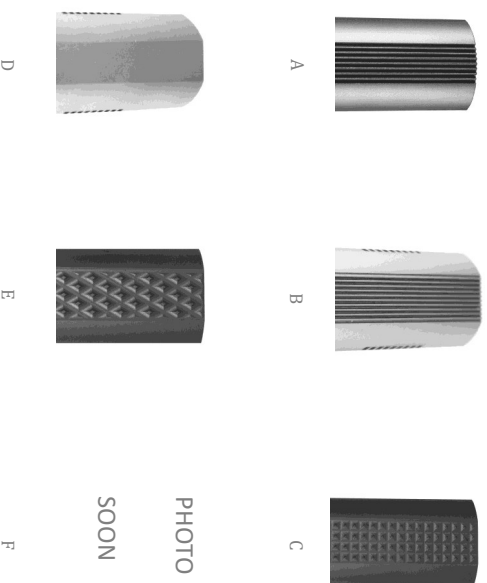

Caspian slides come standard with "Caspian Style" slanted flat bottom serrations. You may specify classic style rear serrations, either vertical or slanted at no extra charge.

Serrations

Caspian style, classic slanted or classic vertical.

Front serrations.....\$50.00

Rear serrations free of charge.

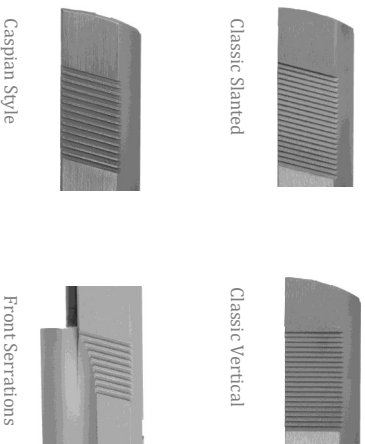

Slide Texture Options

Diamond

Diamond plate offers a mildly aggressive grip and gives your pistol an attractive attitude.

Diamond Slanted Front Serrations.....\$70.00
Diamond Slanted Rear Serration.....\$70.00

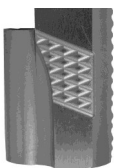
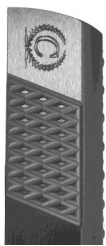

Knurling

Knurling is our most aggressive gripping surface and gives a heavy duty look to your pistol.

Knurling Front Serrations.....\$70.00
Knurling Rear Serrations.....\$70.00



Additional Options

Reverse Plug Cut

Accommodates the collar type reverse plug used with bull barrels. **Non collar type will void the warranty of the slide.**

Reverse Plug Cut RVS.....\$25.00



Bevel Package

For comfortable carry, we will chamfer the sides of the slide as well as the muzzle and rear corners.

Bevel Package BEVEL.....\$45.00



Receiver Options

Custom Serial Number

Great for adding that personal touch. Custom serial numbers must contain at least one number and one letter a max of eleven spaces. Custom serial numbers must be researched for availability prior to applying to ensure there are no duplicates. We do not accept what we find offensive or profane, our decision is final.

Custom Serial Number SPNO.....\$70.00



Ramp Cuts

.38s/9mm are the default. Please specify the caliber you will require when placing your order.

.38s/9mm or .45acp



Ramped Barrel Cuts

Machined out feed ramp and bridge on receiver to accept supported ramped barrels. Cut may need to be modified by pistolsmith to accommodate variations from different barrel manufacturers.

Wilson/Nowlin style or Clark/Para style.....\$70.00

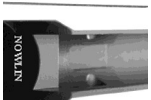

Beavertail Cuts

Our beavertail radius cuts are left a little on the plus side to insure a nice tight fit.

Caspian Wilson Style BV.....\$25.00
.250 Radius BV2.....\$25.00

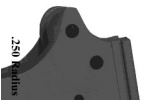

Drill and Tap for Scope Mount

10 6/40 holes to accept the Caspian Weigand pattern scope mounts or the 6 for C-More pattern mounts.

Drill and Tap 10 Hole D&T.....\$40.00
Drill and Tap 6 Hole D&T2.....\$40.00



Receiver Profile Options

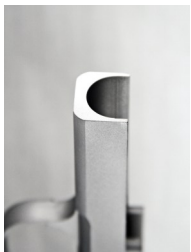

Crew Cut

Crew Cut-square w/rounded corners on the receivers dustcover matching the Cre Cut on the top of the slide.

CREWR.....\$60.00

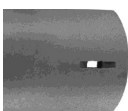

GI Front Post

Series 70 front tenon cut for standard sights as per the military print.

GI front post GIF.....\$25.00

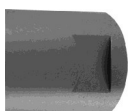

Heinie Style Front Dovetail

.300 X .060 X 60° accommodates the Heinie and many other popular front sights.

Heinie style front dovetail HNEF.....\$30.00



Hi & Tight

High & Tight-Tri-Top style on the receivers dustcover matching the High & Tight on the top of the slide.

HI&TIGHTR.....\$60.00

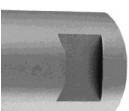

Integral Plunger Tube

A loose plunger tube could prevent you from taking your gun off safe. Our integral plunger solves this common problem and looks great.

Integral Plunger Tube INPPT.....\$30.00

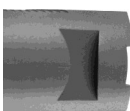

Tactical Option

The tactical option allows for easy stripping of stuck magazines. Only available on Race Ready style receivers.

Tactical TACT.....\$25.00

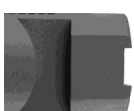

Novak Low Mount Style Rear Dovetail

This cut accommodates the Novak fixed sight, Caspian tactical adjustable, Champion combat sight, and several others.

Novak Low Mount Style Rear Dovetail NVKR.....\$55.00



Cut for the Ed Brown Bobtail

We cut the receiver and drill the hole to accept the Ed Brown Bobtail mainspring housing. Minor fitting required. Mainspring housing not included.

Ed Brown Bobtail Cut BOB.....\$60.00



Novak Adjustable Style Rear Dovetail

For the Novak adjustable sight only.

Novak adjustable style rear dovetail NVKA.....\$55.00

Slide Sight Cut Options

Slide Sight Cut Options

Bomar Style Adjustable Rear

For that deluxe melted in look.

Bomar adjustable rear

BMR.....\$70.00

Hidden Bomar Adjustable Rear

Buries your sight safely into the slide to protect it during hard use situations.

Hidden Bomar adjustable rear

BMRH.....\$70.00

Elliason Style Rear

Cut and pin hole for Elliason sight, flat top is recommended.

Elliason Style Rear

ELL.....\$70.00

RMR Rear

Triflcon RMR/SRO mount rear sight plate cut, SKU: CA428-C-600757

RMR Rear

RMR.....\$70.00

Caspian Race Ready Adjustable

Sights

EDMed and heat treated for precision and strength.

Caspian's unique blade design satisfies today's shooter.

Please specify Bomar Style or LPA.

Available in A. **Target blade** sports a fully serrated blade radius at the corners and flared to match slide. B. **Ghost blade** for the fast acquisition at close to medium distances, perfect for fiber optic sights and **Patented C. Diamond blade** increases long range accuracy when using fiber optic front sights. Reference points for windage and elevation lets your eye center the dot naturally.

Adjustable sight.....\$85.00

11

Recon Receiver

Designed to be strong and compact the recon receiver delivers that bold look.

Available in Carbon Steel, Stainless Steel.

Carbon Steel.....\$325.00

Stainless Steel.....\$340.00



Race Ready Receiver

Lightning fast magazine changes are easier than ever on the Race Ready receiver. With our integral magazine well and the corresponding mainspring housing, smooth contours without ugly seams enhance the lines of your pistol, the 360° race design allows for full engagement.

Specify arched or flat mainspring housings:

Carbon Steel.....\$350.00

Stainless Steel.....\$365.00



Race Ready Recon Receiver

Combining the versatility of an integral magwell with our built in rail provides the tactical shooter with the most advanced 1911 receiver on the market.

Specify arched or flat mainspring housing.

Carbon Steel.....\$430.00

Stainless Steel.....\$445.00



16

When Ordering Caspian Receivers

- Caliber's available .38s/9mm, 40sw/10mm & 45acp.
- All models available in Officer, Commander & Government. Excluding race ready double stack model which is not available in the officer size.
- You may order a Government length dustcover when ordering an Officer's or Commander model.
- Commander rails may be ordered on Race Ready & Double stack receivers. The handle will remain at the Government length
- Commander rails may be ordered on Recon receivers. The Recon rail/dust cover will remain at the standard Government Recon rail length.
- Race Ready Models and the Double Stack come with a mainspring housing. Specify arched or flat.



Classic Receiver

If you're looking to rebuild history then look no further. The classic receiver offers the simple beauty of the original 1911 pistol with today's top notch structure and performance.

Carbon Steel.....\$235.00
Stainless Steel.....\$250.00



Modern Receiver

Our most popular model the modern receiver has all the enhancements you'd want for added speed and accuracy. The modern receiver offers the A1 cuts, higher sweep under the trigger guard, beveled magwell and a smaller window under the grip.

Carbon Steel.....\$230.00
Stainless Steel.....\$245.00

Slide Components

Acrylic Sights

Comes with the popular .040 fiber rods in red & green. Heine Dovetail, .040 Fiber Extra Fiber. Comes with 2 pieces of 3" Fiber rods per package.

Acrylic sights\$35.00
Green, red or clear fiber.....\$10.00



Firing Pin

Light weight design with oil retention rings to reduce friction. 17-4 stainless for strength and resistance.

.38s/9mm S19385.....Out of Stock
45acp S19455.....\$15.00

Classic Firing Pin, Carbon Steel
45acp S1945C.....\$15.00



Firing Pin Retainer

Available in .38s/9mm and 40sw/10mm or 45acp Caspian officer and commander slides come equipped with the .38 ejector slots. Therefore will require the 38s/9mm firing pin retainer.

Carbon S2038B/S2045B.....\$25.00
Stainless S2038S/S2045S.....\$30.00



Standard Guide Plugs

Available in stainless only.

5" hole S22H5C.....\$15.00
6" no hole S22N6C.....\$25.00
6" hole S22H6C.....\$25.00



Reverse Guide Plugs

Popular collar types available in stainless only.

Officer S22R3C.....\$15.00
Commander S22R4C.....\$15.00
5" S22R5C.....\$15.00
6" S22R6C.....\$25.00





Trench Sight Cut

Perfect solution for the Officer or Commander Model slides for your carry build. The trench cut is recessed the full length along the top of the slide.

TRENCH\$30.00



Thumb Safety

Single slide design, 4140 material, blued or 410 stainless steel.

Thumb Safety, blued

R161SB.....\$45.00
R161SS.....\$50.00



Rifling, Receiver Texture

Texturing on the front strap of the receiver giving you the look of Rifling. Also available on your mainspring housing.

Rifling, front strap, CKRF\$105.00
Rifling, back strap RPSH\$50.00



Rifling, Slide Texturing

Texturing on top radius of the slide to complete your Rifling look.

Rifling, Top Radius RIFLETOP.....\$100.00





75 Cal Foster Dr.
Wolcott, VT 05680

802-472-6454 Fax 802-472-6709
sales@caspiansarms.com
Open 9am -5pm Monday-Friday

ORDER FORM

NAME _____ PHONE _____

ADDRESS _____

CITY _____ STATE _____ ZIP _____

EMAIL _____

DATE _____ CHECK OR MONEY ORDER ENCLOSED _____

VISA _____ MC _____ DISCOVER _____ AMERICAN EXPRESS _____

CARD # _____

EXPIRATION DATE: _____ SECURITY CODE: _____

SIGNATURE _____

NAME AS IT APPEARS ON THE CARD _____

BILLING ADDRESS _____

CITY _____ STATE _____ ZIP _____

RECEIVERS MUST SHIP TO A DEALER, VALID FFL REQUIRED PRIOR TO SHIPPING

FFL ENCLOSED _____ NAME ON THE FFL _____

PHONE _____ EMAIL _____

CALIFORNIA SHIPMENTS—DOJ NUMBER OF THE FFL HOLDER _____

ALL CALIFORNIA SHIPMENT REQUIREMENTS PRIOR TO SHIPPING

AB 1263 VERIFICATION OF AGE 18 OR OLDER

AB 1263 NOTICE AND ACKNOWLEDGEMENT FORM

